

BANGUNAN TRANSPORTASI BANDAR UDARA

BANDAR UDARA

- Menurut ICAO :
bandar udara adalah area tertentu di **daratan** atau **perairan** (termasuk bangunan, instalasi dan peralatan) yang digunakan baik secara keseluruhan atau sebagian untuk kedatangan, keberangkatan, dan pergerakan pesawat
- Menurut PP No. 71 / 1996:
bandar udara adalah lapangan terbang yang digunakan untuk mendarat dan lepas landas pesawat udara, naik turun penumpang, dan/atau bongkar muat kargo dan/atau pos, serta dilengkapi dengan fasilitas keselamatan penerbangan dan sebagai tempat perpindahan antar moda transportasi

KANSAI AIRPORT, Jepang



INCHEON AIRPORT, Korea



KOMPONEN BANDAR UDARA

- fasilitas pokok di bandar udara, yang meliputi :
 - fasilitas sisi udara (runway, taxiway, apron)
 - fasilitas sisi darat (terminal penumpang, kargo, jalan akses)
 - fasilitas navigasi penerbangan;
 - fasilitas alat bantu pendaratan visual;
 - fasilitas komunikasi penerbangan.
- fasilitas penunjang bandar udara, yang meliputi :
 - fasilitas penginapan/hotel;
 - fasilitas penyediaan toko dan restoran;
 - fasilitas penempatan kendaraan bermotor;
 - fasilitas perawatan pada umumnya;
 - fasilitas lainnya yang menunjang secara langsung atau tidak langsung kegiatan bandar udara.

(PP 70 Tahun 2001 tentang Kebandarudaraan)

Lay-out Bandara

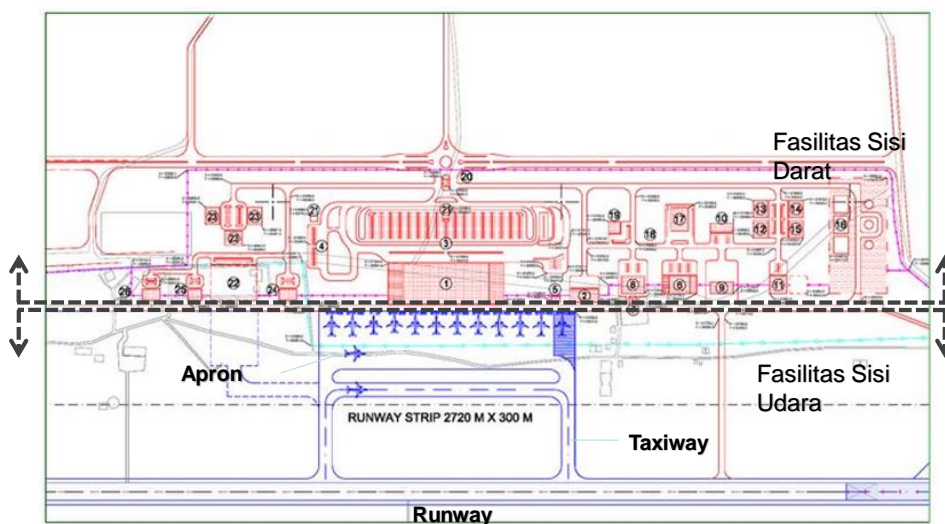

Perspektif Bandara











A typical air trip

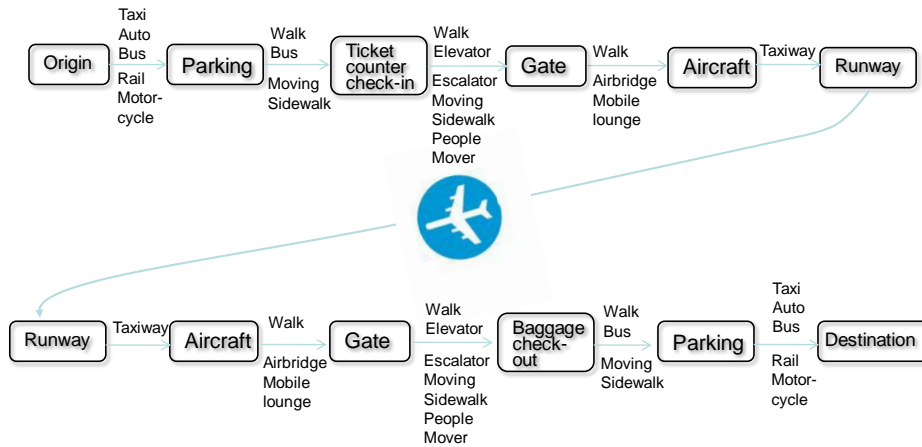

Tata Ruang Terminal Penumpang

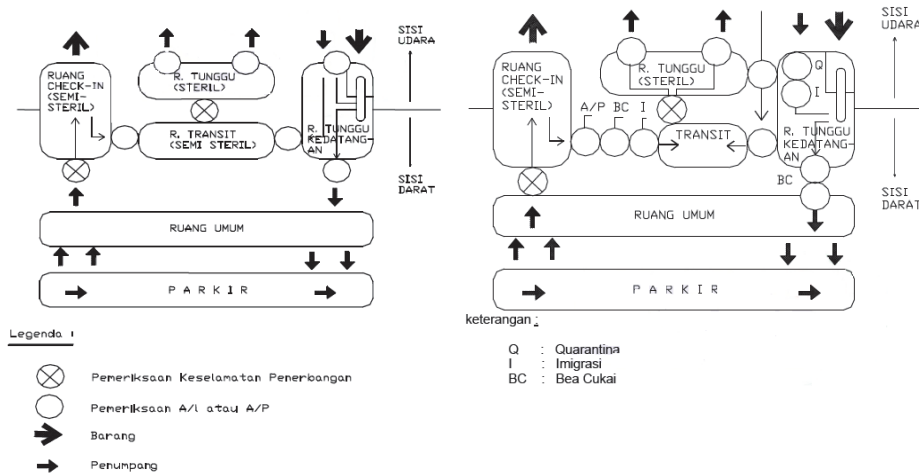

BLOK DOMESTIK

BLOK INTERNASIONAL

Arus pergerakan penumpang dan barang

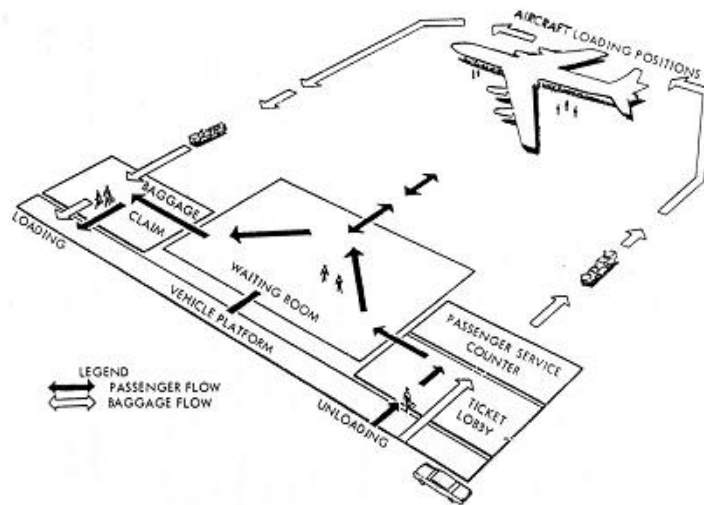

Konsep Distribusi Arus Penumpang

Tujuan: memisahkan arus penumpang yang datang dan berangkat, sehingga tidak terjadi konflik dalam bangunan terminal

Tipe : **1. Distribusi Horisontal**

- Terdiri dari:
- konsep dermaga atau jari
 - konsep satelit
 - konsep linier
 - konsep gabungan

2. Distribusi Vertikal

- Terdiri dari:
- konsep satu level jalan / satu level terminal
 - konsep satu level jalan / dua level terminal
 - konsep dua level jalan / dua level terminal
 - konsep satu level jalan (dua jalur) / dua level terminal

Konsep Distribusi Arus Penumpang

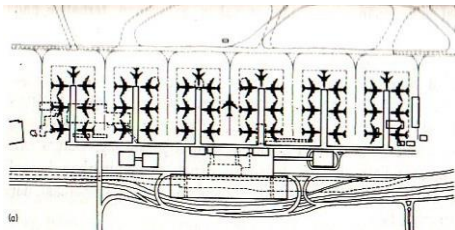

Konsep Dermaga Panjang

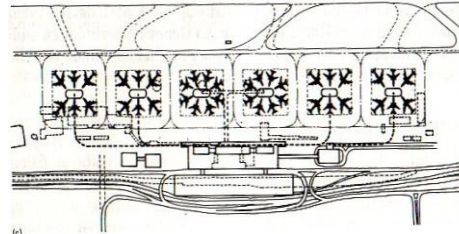

Konsep Satelit

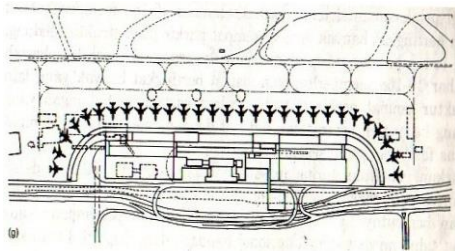

Konsep Linier

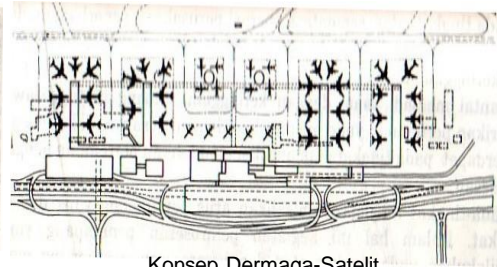

Konsep Dermaga-Satelit

Konsep Distribusi Arus Penumpang



konsep satu level jalan / satu level terminal



konsep satu level jalan / dua level terminal



konsep dua level jalan / dua level terminal



konsep satu level jalan (2 jalur) / satu level terminal

▷ : Penumpang berangkat
datang

◀ : Penumpa
datang

KOMPONEN BANDAR UDARA



Minangkabau International Airport

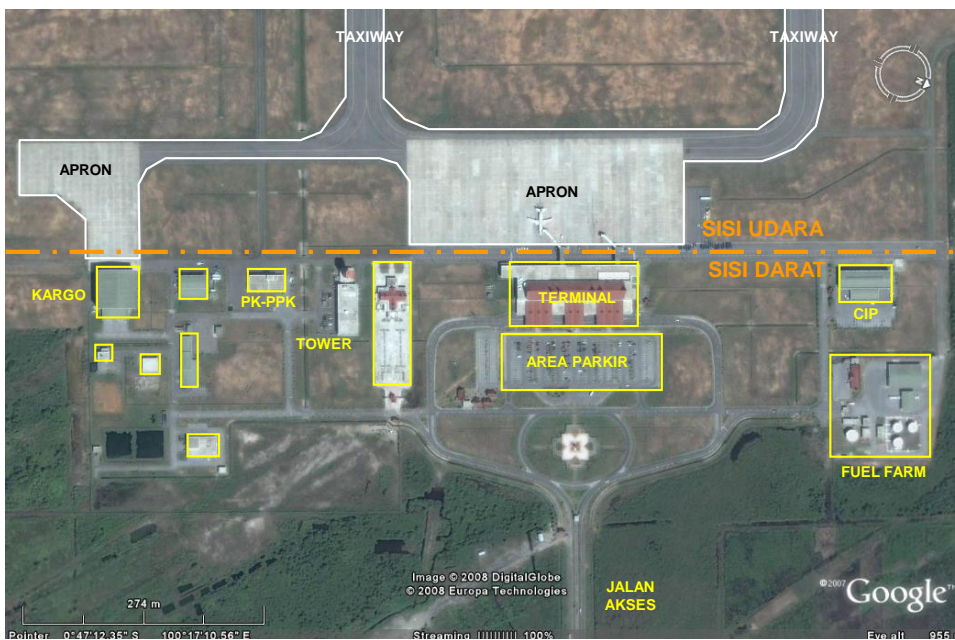

Lay-out Bandara Adi Sucipto

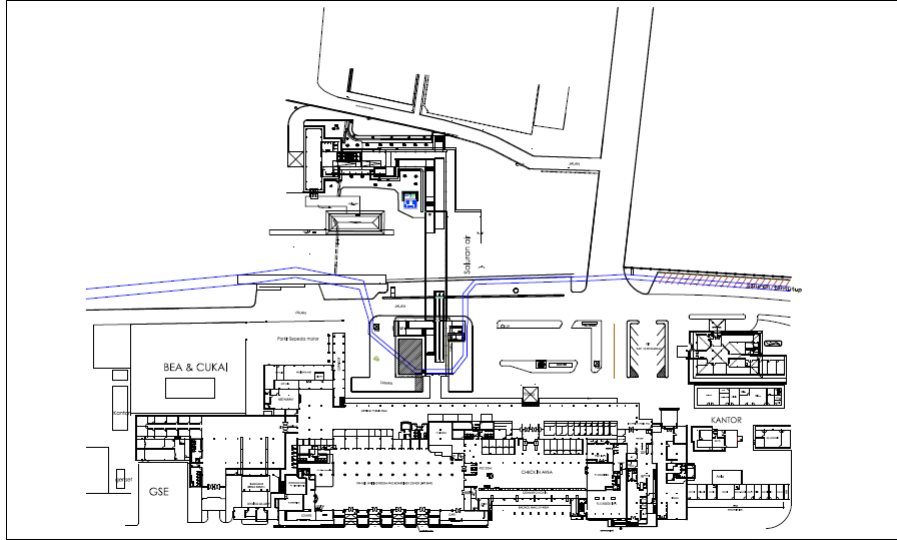

Paris Airports - Charles de Gaulle

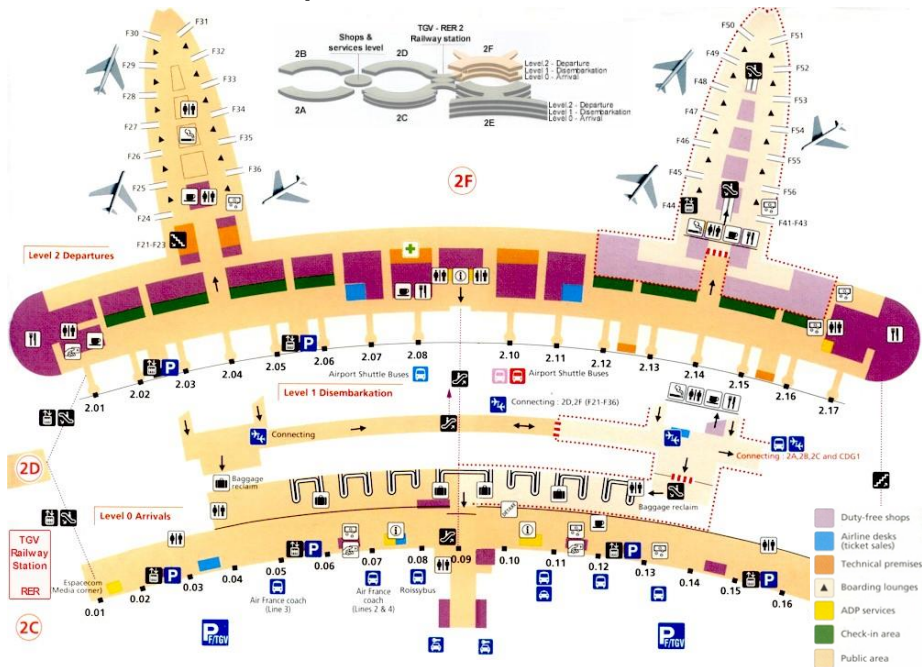

Minangkabau International Airport



Minangkabau International Airport

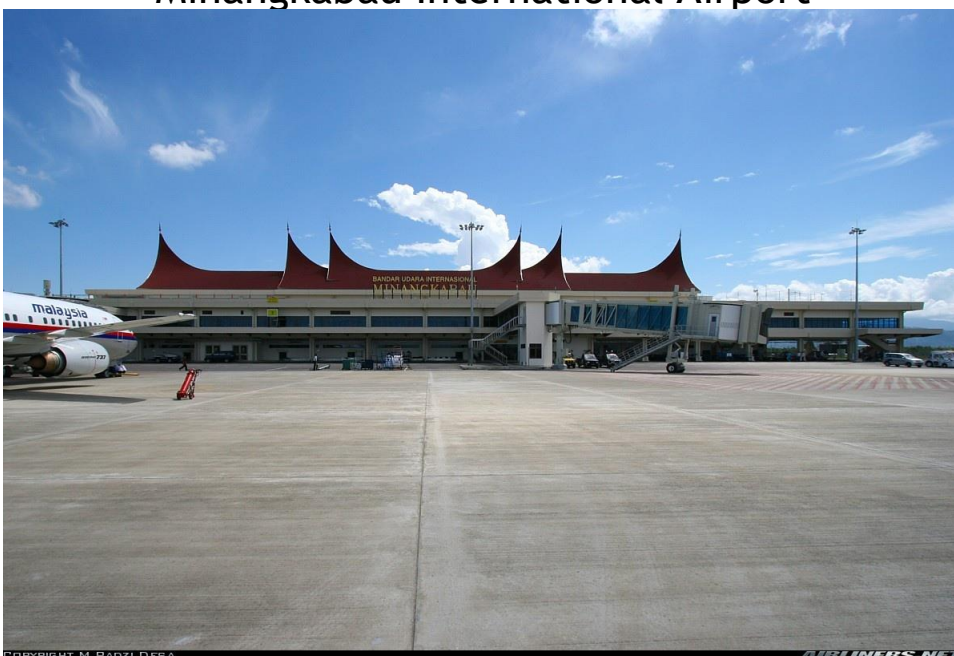

Soekarno-Hatta International Airport

Bandara tersibuk di Indonesia:
- 30 juta pnp/thn
- 250 ribu pergerakan pswt/ thn



Soekarno-Hatta International Airport



Soekarno-Hatta International Airport



Soekarno-Hatta International Airport



Changi, Singapore International Airport

Bandara No. 23 tersibuk di dunia (2008):
- 25 juta pnp/thn
- 214 ribu pergerakan pswt/ thn



Changi, Singapore International Airport



Changi, Singapore International Airport



Changi, Singapore International Airport





Hongkong International Airport

Kondisi 2008:
- 32,6 juta pnp/thn
- 295 ribu pergerakan pswt/thn



Hongkong International Airport



O'Hare Chicago International Airport

Bandara No. 2 tersibuk di dunia (2008):
- 48 juta pnp/thn
- 959 ribu pergerakan pswt/thn



O'Hare Chicago International Airport



O'Hare Chicago International Airport



O'Hare Chicago International Airport



Hartsfield-Jackson Atlanta Intl. Airport

Bandara tersibuk di dunia (2008):
- 61 juta pnp/thn
- 994 ribu pergerakan pswt/thn



Hartsfield-Jackson Atlanta International Airport

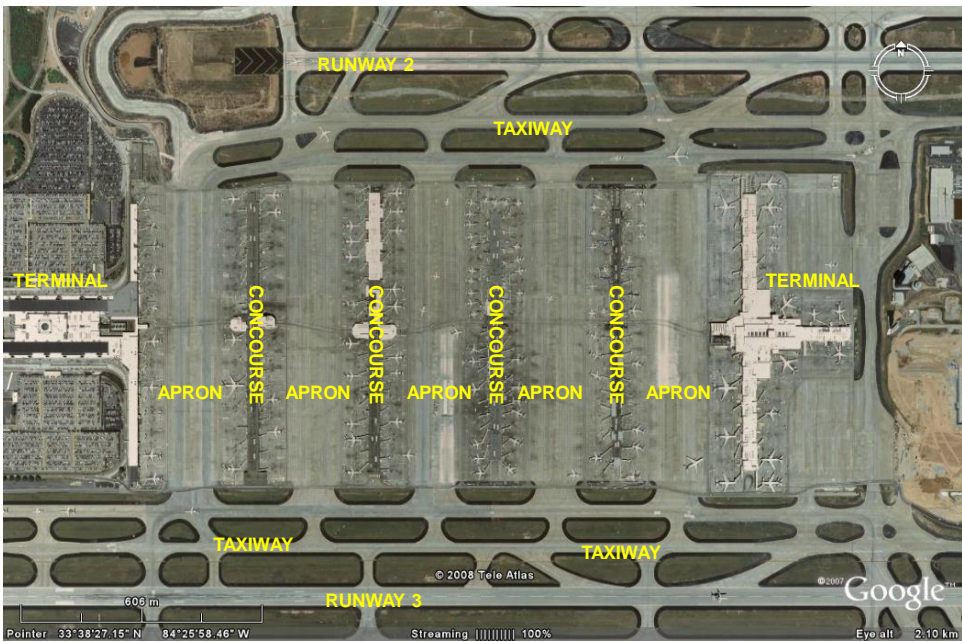

Hartsfield-Jackson Atlanta International Airport



Hartsfield-Jackson Atlanta International Airport

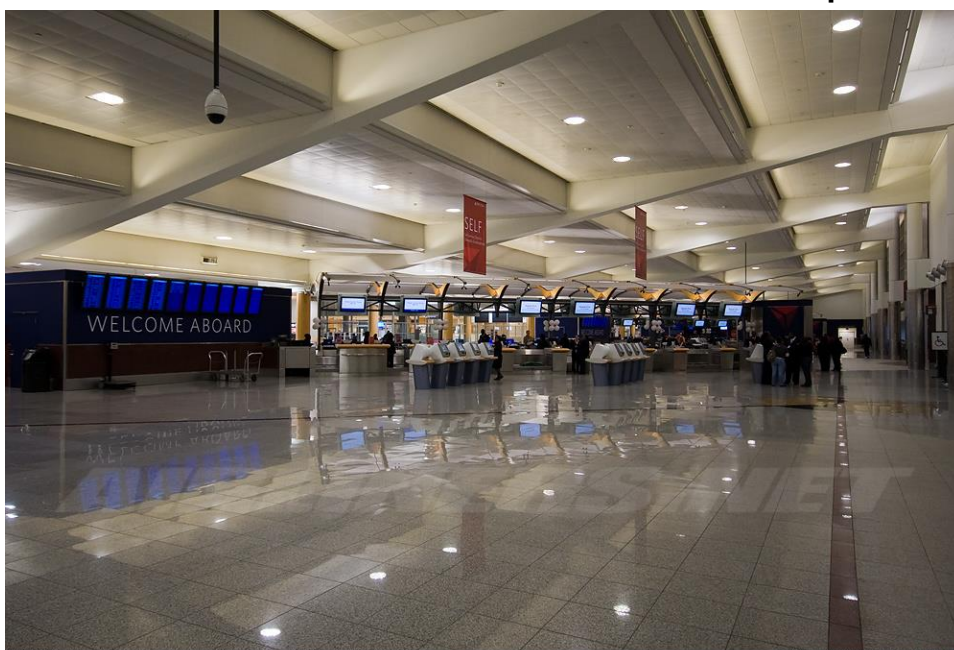





WALK IN INTERVIEW PRAMUGARI GARUDA INDONESIA
Andakah Yang Kami Cari?

